

LLUMAR® PLATINUM PAINT PROTECTION FILM

Technical Reference



Tack solution: alcohol to water ratio with > 90% isopropyl alcohol

Recommended 10% alcohol (or less) to 90% water



Maximum 20% alcohol to 80% water



Not recommended > 30% alcohol to 70% water



Tack solution: alcohol to water ratio with 70% isopropyl alcohol

Recommended 15% alcohol (or less) to 85% water



Maximum 25% alcohol to 75% water



Not recommended > 40% alcohol to 60% water



Film construction

- Masking sheet | 2 mil**
Removable protective polyester film
- Clear coat | 0.26 mil**
Flexible, self-healing coating with an advanced hydrophobic surface
- Urethane | 6 mil**
Impact-resistant 6 mil urethane formulated for excellent UV, heat and water resistance
- Adhesive | 1.2 mil**
Self-crosslinking acrylic copolymer adhesive formulated for balanced tack, adhesive and cohesive properties
- Liner | 3.5 mil**
Matte, polyester release liner

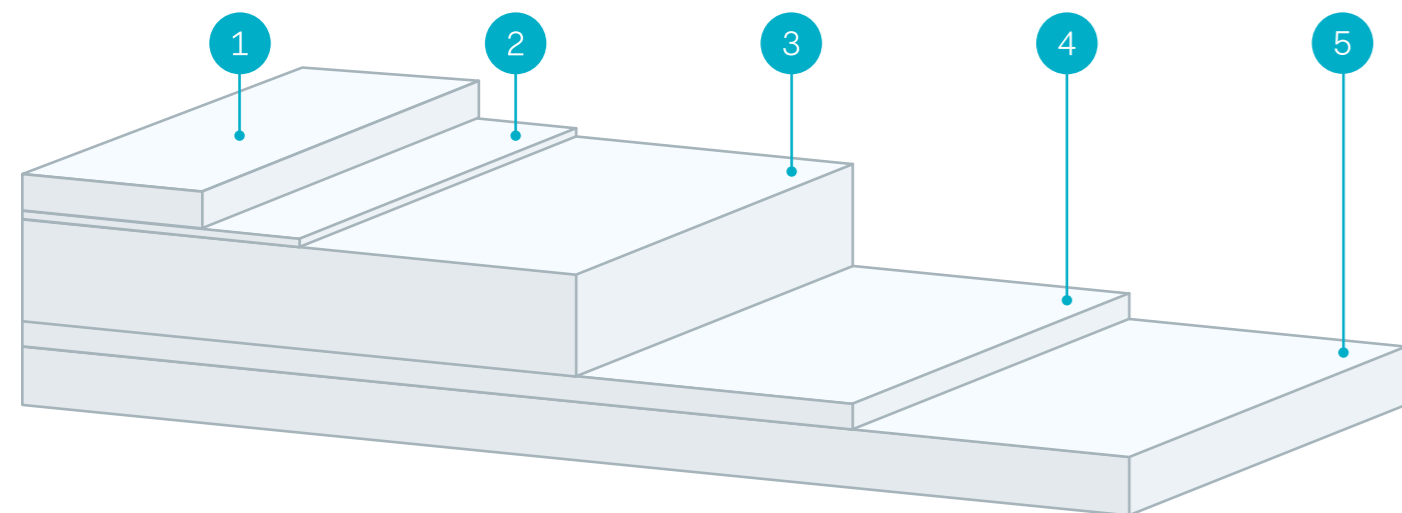

LLUMAR® PLATINUM PAINT PROTECTION FILM

Care & Warranty



Care

To maintain the life and look of the LLumar® Platinum Paint Protection Film and to ensure warranty coverage, do NOT wash or wax vehicle for a minimum of three days following product installation. Following this three-day period, frequent washing and waxing is recommended.

Ten-year limited warranty* coverage

The Manufacturer warrants professionally sold and applied LLumar Platinum Paint Protection Film (PPF-Gloss, PPF-Matte as applicable) (the "Product") against cracking, bubbling or discolouring caused solely by defects in manufacture or materials, for a period of ten years from the date of purchase of the Product. This warranty is valid only if the product application was performed by a LLumar installer in accordance with Manufacturer's application procedures and applicable law.

*Certain restrictions apply; see an authorised dealer for warranty details.

LLumar® Self-Healing Platinum Paint Protection Film

Installation & technical data guide

LLumar® Paint Protection Film (PPF) offers breakthrough technology for paint protection applications using an advanced, self-healing, solvent-resistant clear coat formulation allowing for easy installation and increased longevity.

FOLLOW THIS GUIDE FOR PROPER PRACTICES & TECHNIQUES



Features & benefits

- Virtually invisible protection from damage caused by rocks, salt, insects and other road debris
- A proprietary, self-healing clear coat that is scratch and crack-resistant with a high-gloss finish
- Advanced water resistant surface for increased durability with **Hydrogard™** technology
- Superior optical clarity
- **Ten-year** Manufacturer's limited warranty*

Application & storage

- For detailed product information and installation videos of LLumar Platinum Paint Protection Film visit www.LLumar.com
- Recommended installation environment temperature should be within 15.5°C - 32°C (60°F to 90°F)
- Recommended installation solution (tack solution): 15% of 70% isopropyl alcohol diluted with 85% distilled water
- Required product storage conditions of 15.5°C - 32°C (60°F to 90°F)

Product Availability

Mat. no.	Description	Dimension	
50198618	LLumar Platinum Paint Protection Film, gloss	0.609 m x 30.48 m	24" x 100'
50198697		0.914 m x 30.48 m	36" x 100'
50198614		1.219 m x 30.48 m	48" x 100'
50198616		1.524 m x 15.24 m	60" x 50'
50198619	LLumar Platinum Paint Protection Film, matte	1.219 m x 30.48 m	48" x 100'
50198612		1.524 m x 15.24 m	60" x 50'

LLumar PrecisionCut® System

Installers will save time and improve efficiency with our innovative film-cutting tool for paint protection film. Helps to minimise liability and quality concerns by eliminating cutting on the vehicle. Our pattern database for paint protection film is organized by vehicle year, make, model and trim. Our patterns include hoods, bumpers, fenders, mirrors, headlights, rockers, roofs, A-pillars, rear fenders and rear bumpers.

EASTMAN

LLumar.com

©2018 Eastman Performance Films, LLC. Product brands referenced herein with a ™ or ® symbol are trademarks of Eastman Chemical Company or its subsidiaries. All other trademarks are the property of their respective owners. Visual renderings are for illustrative purposes only; actual appearance may vary. All rights reserved. No liability is accepted for errors. 01/18

LLUMAR® PLATINUM PAINT PROTECTION FILM

Technical Data



Performance properties			
Performance tests are conducted using standard test procedures. LLumar® Platinum Paint Protection Film meets or exceeds the minimum specification values shown below.			
Product Thickness (Total)	7.5 mil	(189.4 microns)	
Thickness (Clear Coat)	0.26 mil	(6.5 microns)	
Thickness (Base Film)	6.0 mil	(152.4 microns)	
Thickness (Adhesive)	1.2 mil	(30.5 microns)	
Thickness (Liner)	3.5 mil	(88.9 microns)	
Peel Adhesion	72 oz/in	(804 N/m)	ASTM D3330
Tensile Strength	5000 psi	(34.5 Mpa)	ASTM D638 - 10
Elongation at Break	>400%		ASTM D638 - 10
Chemical Resistance	Isopropyl Alcohol	No Detrimental Effect	ASTM D7244, ASTM D6279
Chemical Resistance	Heptane / Hexane / Toluene	No Detrimental Effect	ASTM D7244, ASTM D6279
Weathering	QUV 2500h	No Detrimental Effect	ASTM G153
Weathering	Xenon 2500h	No Detrimental Effect	SAEJ1960
Weathering	Xenon 2500h	No Detrimental Effect	ASTM G155
Staining ¹	Transmission Fluid, Antifreeze, Windshield Washing Fluid, Used Motor Oil, Ketchup, Mustard	Resilient	ASTM E313-98
Acid Immersion	10% Sulfuric Acid; 72 hours	No Detrimental Effect	
Base Immersion	10% Sodium Hydroxide	No Detrimental Effect	
Rock Chip Resistance ²	SAE J400 Gravelometer	Pass	water-worn road gravel, 3/8" to 5/8" mesh

Note: All statements, technical information and recommendations herein are based on tests Eastman believes are reliable. Eastman does not warrant or guarantee the accuracy or completeness of this information.

STAIN TEST¹

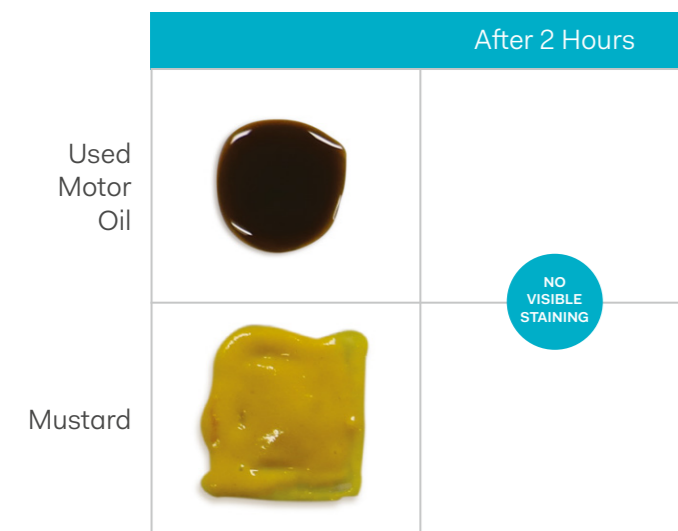

ROCK TEST²



Image represents gravel impact testing on surface paint.

LLUMAR® PLATINUM PAINT PROTECTION FILM

Installation



Recommended installation tools

- Yellow Turbo
- Black Tube Squeegee
- Detailing Squeegee
- Johnson's® Baby Shampoo
- Distilled Water
- 70% Isopropyl Alcohol
- Olfa Knife
- (2) Spray bottles
- Lint-Free Towels
- Clay Bar

Installation solutions

- **Slip Solution** - One bottle (32 oz) of distilled water with two-three droplets of baby shampoo
- **Tack Solution** - 15% of 70% isopropyl alcohol diluted with 85% distilled water (for other ratio recommendations, refer to the technical reference page in this document)

Surface preparation | The ideal installation temperature is between 15.5°C - 32°C (60°F to 90°F)

- Always prep the surface area where the paint protection is applied by using slip solution and cleaning the area of application
- Use a clay bar to clean and remove dirt or debris from the vehicle paint surface then degrease the installation area using your tack solution
- Finally, spray slip solution onto the area and using a squeegee, make one final pass to ensure that no fibers were left behind from the towel

Tips & tricks

- If you get a surface scratch in the film, you can use minimal heat to make the film self-heal
- If you see any debris under the film after installation, you can lift the product with slip solution then reinstall
- Always squeegee away from an area that has already been installed
- If there is a colored mark in the film from installation or after, you can remove this with your tack solution

Hood installation

- Spray slip solution on the hood and film
- Peel liner and place the pattern on the hood in the correct alignment
- If needed, use the tack solution underneath the film and position one side of the film, then squeegee into position
- Distribute stretch as needed to reach the opposite side of the hood, then using your tack solution, squeegee out opposite side
- To complete the hood, finish squeegeeing the slip solution out of the middle

Note: If you are using a piece of film that is not a pattern, follow the same steps

LLUMAR® PLATINUM PAINT PROTECTION FILM

Installation & Removal



Mirror installation

- Prep surface area
- Remove liner from the film and place the pattern using your slip solution
- Use your tack solution to lock the film down in the best alignment position
- Stretch the film as needed to finish the mirror using your tack solution

Note: Do not over stretch film and do not use more alcohol to install; this will destroy the adhesive

Fender installation

- Prep surface area
- Remove liner from the film and place the pattern using your slip solution
- Align your pattern into place and use tack solution if needed to complete your install

Bumper installation

- Prep surface area
- Remove liner from the film and place the pattern on the bumper with your slip solution
- Find where the most alignment points are on the vehicle, then use your tack solution to lock into placement (Most of the time the best alignment point is off center of the bumper)
- Use your tack solution and gently stretch the film as needed toward the wheel to complete the compound curve
- Repeat on the opposite side
- Remember to minimize tension around sensors and headlight washers

Note: If you are using a piece of film that is not a pattern, follow the same steps

Removal

- LLumar® Platinum Paint Protection Film can be removed from the vehicle at any time. Simply lift a corner of the film and with a pulling motion, remove at a 30°- 90° angle.
- Steam softens the film and makes it easier to remove. Using the steam removal method, the adhesive stays on the film during removal, requiring less adhesive clean-up. A heat gun or hair dryer can also be used to soften the adhesive. This method may cause the adhesive to split which will require more adhesive to be cleaned off the vehicle.

closed view



LLumar® Self-Healing Platinum Paint Protection Film Installation & technical data guide

LLumar® Paint Protection Film (PPF) offers breakthrough technology for paint protection applications using an advanced, self-healing, solvent-resistant clear coat formulation allowing for easy installation and increased longevity.

FOLLOW THIS GUIDE FOR PROPER PRACTICES & TECHNIQUES

Features & benefits

- Virtually invisible protection from damage caused by rocks, salt, insects and other road debris
- A proprietary, self-healing clear coat that is scratch and crack-resistant with a high-gloss finish
- Advanced water resistant surface for increased durability with **Hydregard™** technology
- Superior optical clarity
- **Ten-year** Manufacturer's limited warranty*

Application & storage

- For detailed product information and installation videos of LLumar Platinum Paint Protection Film visit www.LLumar.com
- Recommended installation environment temperature should be within 15.5°C - 32°C (60°F to 90°F)
- Recommended installation solution (rock solution): 15% of 70% isopropyl alcohol diluted with 85% distilled water
- Required product storage conditions of 15.5°C - 32°C (60°F to 90°F)

Product Availability

Mat. no.	Description	Dimension
50198618	LLumar Platinum Paint Protection Film, gloss	0.609 m x 30.48 m
50198697		0.914 m x 30.48 m
50198614	LLumar Platinum Paint Protection Film, matte	1.219 m x 30.48 m
50198616		1.524 m x 15.24 m
50198619	LLumar Platinum Paint Protection Film, matte	1.219 m x 30.48 m
50198612		1.524 m x 15.24 m

LLumar PrecisionCut® System

Installers will save time and improve efficiency with our innovative film-cutting tool for paint protection film. Helps to minimise liability and quality concerns by eliminating cutting on the vehicle. Our pattern database for paint protection film is organized by vehicle year, make, model and trim. Our patterns include hoods, bumpers, fenders, mirrors, headlights, rockers, roofs, A-pillars, rear fenders and rear bumpers.

inside view

LLUMAR® PLATINUM PAINT PROTECTION FILM

Technical Data

Performance properties	Value	Test Method
Thickness (Minimum Edge)	75 µm	(100 µm maximum)
Thickness (Base Film)	6.0 µm	(100 µm maximum)
Thickness (Protective)	3.5 µm	(100 µm maximum)
Flex Adhesion	1.2 MPa	(100 µm maximum)
Impact Strength	22 mJ/m²	(100 µm maximum)
Elongation at Break	300%	(100 µm maximum)
Chemical Resistance	100%	(100 µm maximum)
Weathering	100%	(100 µm maximum)
Wearability	100%	(100 µm maximum)
Scratching	100%	(100 µm maximum)
Acid Resistance	100%	(100 µm maximum)
Heat Resistance	100%	(100 µm maximum)
Rock Chip Resistance	100%	(100 µm maximum)

STAIN TEST!

Substance	After 2 Hours
Used Motor Oil	
Mustard	

ROCK TESTS

Condition	Result
No PPE Applied	
PPE Applied	

LLUMAR® PLATINUM PAINT PROTECTION FILM

Installation

Recommended installation tools

- Yellow Turbo
- Black Turbo Squeegee
- Detailing Squeegee
- Johnsen's®
- Baby Shampoo
- Distilled Water
- 70% Isopropyl Alcohol
- Clay Knife
- (2) Spray bottles
- Lint-Free Towels
- Clay Bar

Installation solutions

- Slip Solution** - One bottle (32 oz) of distilled water with two-three drops of baby shampoo
- Tack Solution** - 10% of 70% Isopropyl Alcohol for other roles recommendations, refer to the technical reference page in this document

Surface preparation | The ideal installation temperature is between 15.5°C - 32°C (60°F to 90°F)

- Always prep the surface area where the paint protection is applied by using slip solution and cleaning the area of debris/dirt
- Use a clay bar to clean and remove dirt or debris from the vehicle paint surface then degrease the installation area using your tack solution
- Finally spray slip solution onto the area and using a squeegee, make one final pass to ensure that no fibers were left behind from the towel

Tips & tricks

- If you get a surface scratch in the film, you can use minimal heat to make the film self heal
- If you see any debris under the film after installation, you can lift the product with slip solution then reinstall
- Always squeegee away from an area that has already been installed
- If there is a colored mark in the film from installation or after, you can remove this with your tack solution

Hood installation

- Spray slip solution on the hood and film
- Peel liner and place the pattern on the hood in the correct alignment
- If needed, use the tack solution underneath the film and position one side of the film, then squeegee into position opposite side
- To complete the hood, finish squeegeeing the slip solution out of the middle

LLUMAR® PLATINUM PAINT PROTECTION FILM

Installation & Removal

Mirror installation

- Prep surface area
- Remove liner from the film and place the pattern using your slip solution
- Use your tack solution to lock the film down in the final alignment position
- Stretch the film as needed to finish the mirror using your tack solution

Fender installation

- Prep surface area
- Remove liner from the film and place the pattern with your slip solution
- Remove liner from the film and place the pattern with your tack solution
- Align your pattern into place and use tack solution if needed to complete your install

Bumper installation

- Prep surface area
- Remove liner from the film and place the pattern on the bumper with your slip solution
- Find where the most alignment points are on the vehicle, then use your tack solution to lock into placement (front of the bumper the most alignment point is off center of the bumper)
- Use your tack solution and gently stretch the film as needed towards the wheel to complete the compound curve
- Repeat on the opposite side
- Remember to minimize tension around sensors and headlight modules

Removal

- LLumar® Platinum Paint Protection Film can be removed from the vehicle at any time. Simply lift a corner of the film and with a pulling motion, remove at a 90° angle
- Stretch and warm the film and make it easier to remove. Using the steam removal method, the adhesive stays on the film during removal, ensuring that adhesive doesn't get on your car or hair dryer can also be used to soften the adhesive. This method may cause the adhesive to split which will require extra attention to be cleaned off the vehicle.

outside view

LLumar® Self-Healing Platinum Paint Protection Film

Installation & technical data guide

LLumar® Paint Protection Film (PPF) offers breakthrough technology for paint protection applications using an advanced, self-healing, solvent resistant clear coat formulated exclusively for size, installation and increased longevity.

FOLLOW THIS GUIDE FOR PROPERTIES & TECHNIQUES

Features & benefits

- Visually invisible protection from damage caused by rocks, soil, insects and other road debris
- A scratch-resistant, self-healing clear coat that is scratch and crack resistant with a high-gloss finish
- Advanced water resistant surface for increased durability with **Hydrophobe™** technology
- Superior optical clarity
- **Ten-year** Manufacturer's limited warranty*

Application & storage

- For detailed product information and installation video visit www.LLumar.com
- Recommended installation environment temperature should be within 15.0°C - 32.0°C (60°F to 90°F)
- Recommended installation solution (tack solution): 25% of 50% isopropyl alcohol diluted with 50% distilled water
- Recommended storage conditions of diluted water: 15.5°C - 32°C (60°F to 90°F)

LLumar PrecisionCut® System

Installers will save time and improve efficiency with our innovative film-cutting tool for paint protection film. Helps to minimize labor and quality concerns by automating cutting on the vehicle. Our pattern database for paint protection film is supported by vehicle year, make, model and trim. Our patterns include: hoods, bumpers, fenders, mirrors, headlights, roof, A-pillars, rear fenders and rear bumpers.

Part No.	Description	Dimension
5038835F	LLumar® Platinum Paint Protection Film, matte	0.620 m x 3.302 m (24" x 130")
5038835F		0.914 m x 3.241 m (36" x 128")
5038835F		1.224 m x 3.048 m (48" x 120")
5038835F		1.220 m x 3.241 m (48" x 128")
5038835F		1.524 m x 3.241 m (60" x 128")

LLUMAR® PLATINUM PAINT PROTECTION FILM

Care & Warranty

Care

To maintain the life and look of the LLumar® Platinum Paint Protection Film and to ensure warranty coverage, do NOT wash or wax vehicle for a minimum of three days following product installation. Following this three-day period, frequent washing and waxing is recommended.

Ten-year limited warranty* coverage

The Manufacturer warrants professionally sold and applied LLumar® Platinum Paint Protection Film (PPF) Glass, PPF, Matte or Gloss finish (the "Product") against cracking, bubbling or discoloring caused solely by defects in manufacture or materials, for a period of ten years from the date of purchase of the Product. This warranty is valid only if the product application was performed by a LLumar® installer in accordance with Manufacturer's application procedures and applicable law.

LLUMAR® PLATINUM PAINT PROTECTION FILM

Technical Reference

Tack solution: alcohol to water ratio with > 90% isopropyl alcohol

- Recommended: 10% alcohol (or less) to 90% water
- Maximum: 20% alcohol to 80% water
- Not recommended: > 30% alcohol to 70% water

Film construction

1. **Making sheet | 2 mil**
Removable protective polyester film
2. **Clear coat | 0.25 mil**
Flexible, self-healing coating with an advanced hydrophobic surface
3. **Urethane | 6 mil**
Impact resistant 6 mil urethane formulated for excellent UV, heat and water resistance
4. **Adhesive | 1.2 mil**
Self-crosslinking acrylic copolymer adhesive formulated for balanced tack, adhesive and cohesive properties
5. **Liner | 3.5 mil**
Matte, polyester release liner

LLUMAR® PLATINUM PAINT PROTECTION FILM

Technical Reference

Tack solution: alcohol to water ratio with 70% isopropyl alcohol

- Recommended: 15% alcohol (or less) to 85% water
- Maximum: 25% alcohol to 75% water
- Not recommended: > 40% alcohol to 60% water

EASTMAN
© 2018 Eastman Chemical Company. All rights reserved. Product names and other marks are the property of their respective owners. Eastman Chemical Company is not responsible for the accuracy of the information provided herein. For more information, visit www.LLumar.com.